

Remotely Selectable Electronic Siren

Model SST3-MV



ELECTRONIC SIREN WITH THREE REMOTELY SELECTABLE TONES

- Produces three tones – wail, yelp and horn
- Multi-voltage design accepts 24VDC or 120/240VAC
- Produces 111dB @ 10' (121dB @ 1m)
- Omni-directional swivel mount
- UL Listed, cUL Listed
- NEMA 3R, IP54 enclosure (with WB back box)

Federal Signal's SST3-MV is an electronic siren capable of producing three different high decibel tones from the same unit.

The Model SST3-MV features internal amplification and the circuitry required to produce three different tones. The user activates each tone (wail, yelp or horn) with dry contacts from a remote point.

The SST3-MV operates on 24VDC, 120VAC or 240VAC. The NEMA 3R housing is molded from impact resistant ASA (acrylic-styrene-acrylonitrile) plastic, making it resistant to ultra-violet light and ideal for indoor or outdoor use.

The omni-directional swivel mount system allows the output to be pointed anywhere within a 360° half-sphere.

This electronic siren is UL (Underwriters Laboratories) Listed and cUL (Canadian Underwriters Laboratories) Certified.

The Model SST3-MV can be used as a stand-alone, high-output, audible warning device in any application where multiple tones are needed but voice paging is not required.

Typical applications include emergency warning, start and dismissal, fire alarm, general alarm and evacuation.

Federal Signal's Model SST3-MV Electronic Siren is an economical multi-tone siren designed to hold up in the rigors of corrosive environments.

Model	Voltage	Operating Current	Decibels @	
			Tone	10' 1m
SST3-MV	24VDC	600mA	Wail	109.5 119.5
SST3-MV	120VAC	210mA	Yelp	111 121
SST3-MV	240VAC	120mA	Horn	107 117



ELECTRONIC SIREN (SST3-MV)

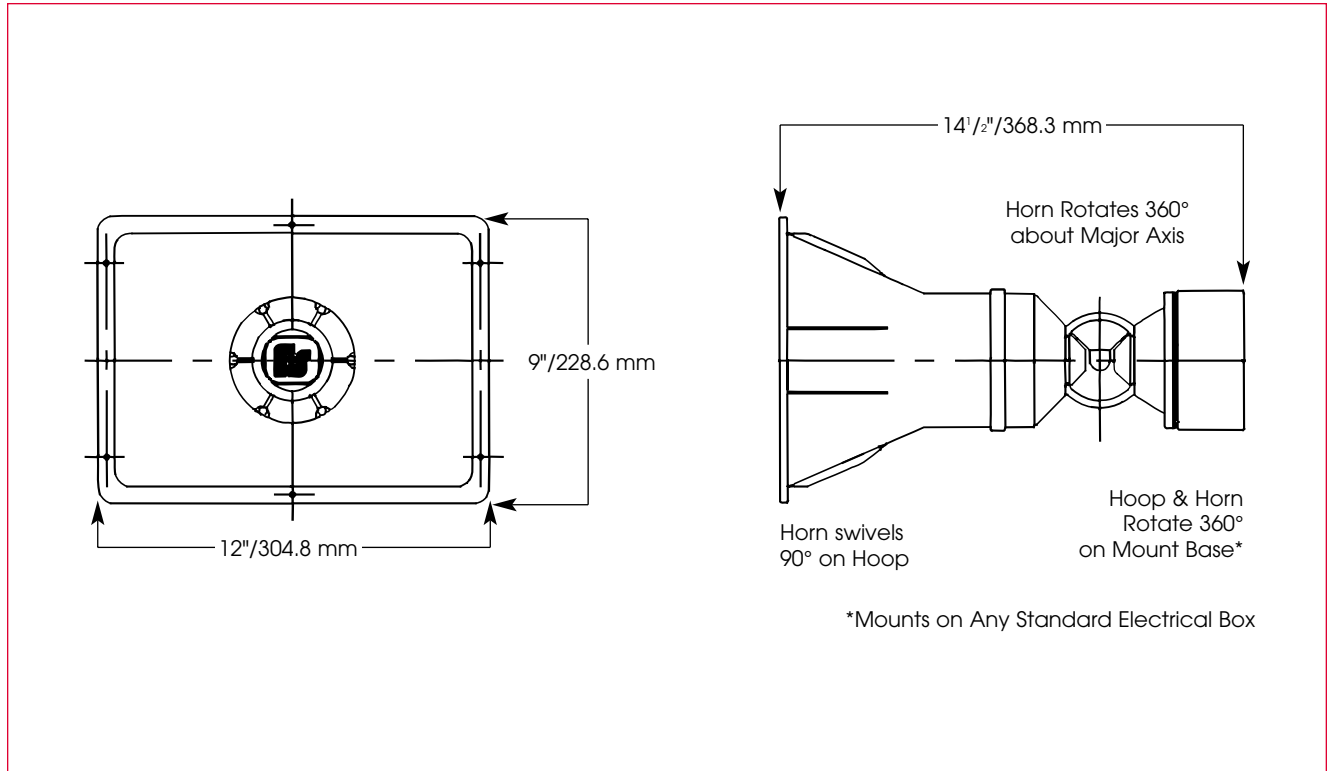

SPECIFICATIONS

Operating Temperature:	-31°F to 161°F	-35°C to 72°C
Net Weight:	4.5 lbs.	2.0 kg
Shipping Weight:	5.2 lbs.	2.4 kg
Height:	14.5"	368 cm
Width:	12"	305 cm
Depth:	9.0"	229 cm
Maximum Contact Resistance	1000 ohms	1000 ohms

HOW TO ORDER

- Specify model
- Specify options:
Weatherproof Backbox (WB)
4" Electrical Box (NB)

REPLACEMENT PARTS

<u>Description</u>	<u>Part Number</u>
PC Board Assembly	K2005110A
Connector, 4-Position	K140340B
Adapter	K8476121A
Gasket	K8476122A