



Explosion-Proof Strobe Light

Model 27XST

DESIGNED FOR USE IN EXPLOSION-PROOF ATMOSPHERES

- Available in 24VDC, 120VAC and 240VAC
- Six lens colors
- 10,000 hour, strobe tube
- 3/4-inch pendant mount standard
- Dome guard optional
- UL Listed, CSA Certified
- NEMA 4X, IP66 enclosure
- Marine Rated

Federal Signal's Model 27XST explosion-proof strobe light produces 80 high-intensity flashes per minute. This warning light operates on 24VDC, 120VAC, and 240VAC 50/60Hz.

The 27XST is UL Listed for Class I, Division 1, Groups C & D; Class II, Division 1, Groups E, F & G; Class I, Division 2, Groups A, B; and Class III. The 27XST is CSA Certified and Marine Rated.

The 27XST is NEMA Type 4X rated; constructed to IP66. Corrosion resistance is achieved with a powder epoxy finish applied over the copper-free aluminum housing. All exposed hardware is 316 grade stainless steel.

Federal Signal's Model 27XST has an effective candlepower (ECP) of 850 and a two million peak candlepower. A pendant mount is supplied and a ceiling mount, 25° stanchion mount and 90° wall mount are available options. For easy installation, the mounting box is first installed and the fixture is then threaded onto the mounting box, making the electrical connection. Electrical continuity is made when five threads are engaged.

Federal Signal's Model 27XST is specifically designed for explosion-proof atmospheres and/or corrosive environments. Because it is easy to install and requires very low maintenance, it is ideal for use in areas such as oil rigs, mines, refineries, and chemical plants.

Model	Voltage	Operating Current	Flash Rate/Minute	Candlepower Peak ¹	ECP ²	Mount
27XST	24VDC	1.25 amps	80	2,000,000	850	3/4" Pendant
27XST	120VAC 50/60Hz	0.60 amps	80	2,000,000	850	3/4" Pendant
27XST	240VAC 50/60Hz	0.30 amps	80	2,000,000	850	3/4" Pendant

¹ Peak candlepower is the maximum light intensity generated by a flashing light during its light pulse

² ECP (Effective Candlepower) is the intensity that would appear to an observer if the light were burning steadily



EXPLOSION-PROOF STROBE LIGHT (27XST)

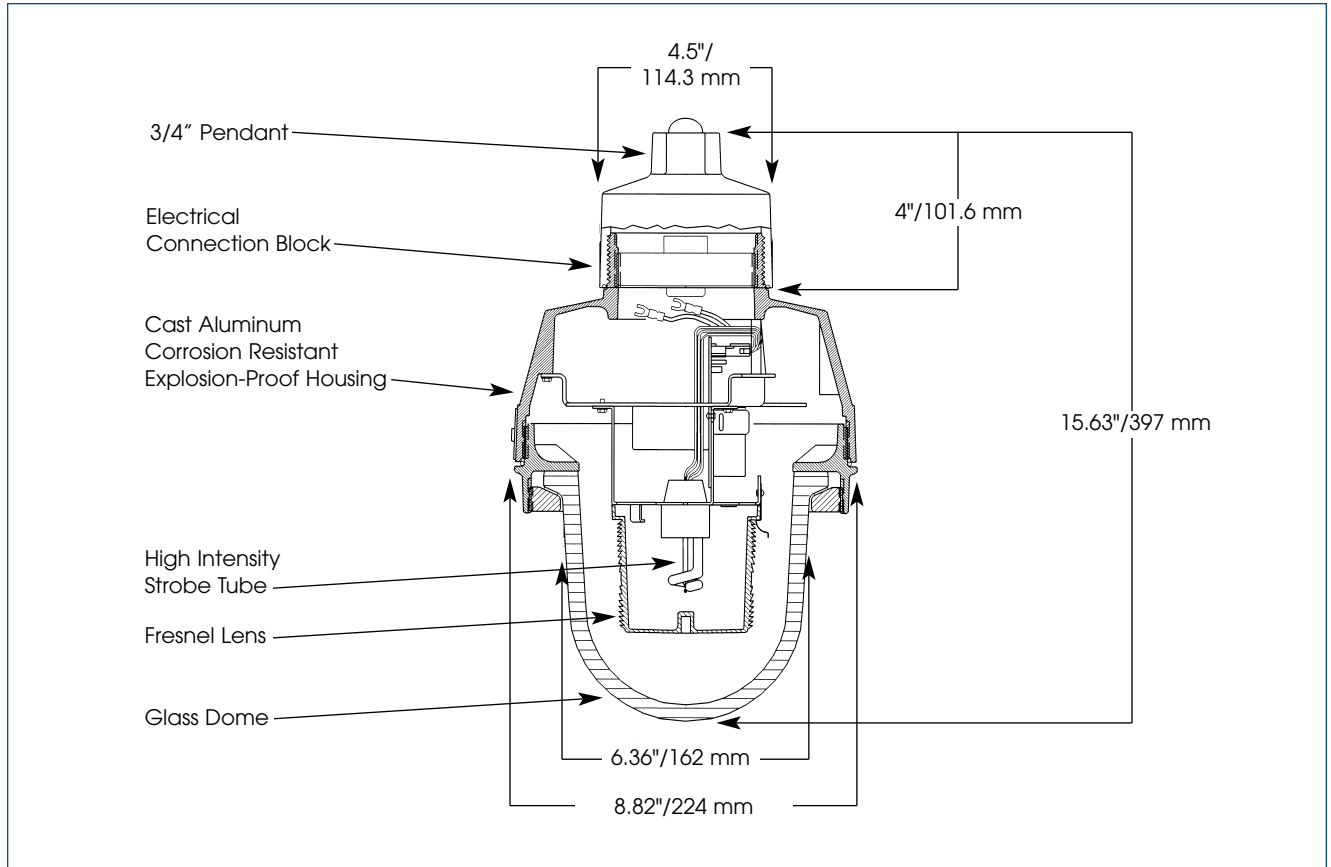

SPECIFICATIONS

Lamp Life*:	10,000 hours	10,000 hours
Lamp Style:	Strobe	Strobe
Net Weight:	14 lbs.	6.4 kg
Shipping Weight:	18.1 lbs.	8.2 kg
Height:	15.63"	397 mm
Diameter:	8.82"	224 mm

* Optimal hours under ideal conditions.

HOW TO ORDER

- Specify model, voltage and color (Magenta upon request)
- Specify options:
 Dome Guard (DGXC)
 Ceiling Mount (CMXC)
 Wall Mount (WMXC)
 25° Stanchion Mount (SMXC)

REPLACEMENT PARTS

Description	Part Number
Exterior Dome Assembly, Clear	K8444C271A-01
Interior Lens Assembly, Amber	K8550C095A-02
Interior Lens Assembly, Blue	K8550C095A-01
Interior Lens Assembly, Clear	K8550C095A
Interior Lens Assembly, Green	K8550C095A-04
Interior Lens Assembly, Red	K8550C095A-03
24VDC Mechanism	K8436107E-03
120VAC Mechanism	K8436107D-02
240VAC Mechanism	K8436107D-01
Strobe Tube, Series C	K8107178A
Strobe Tube, Series C-1, C-2	K8107159A