



Explosion-Proof General Alarm Siren

Model AX

DESIGNED FOR USE IN EXPLOSION PROOF ATMOSPHERES

- Available with 120VAC/125VDC universal motor
- Produces 112dB @ 10' (122dB @ 1m)
- 3/4" pipe mount
- Maintenance free
- UL Listed, CSA Certified
- NEMA 3R, IP55 enclosure

The Federal Signal Model AX siren was introduced in 1937 and received UL listing in 1938. This high pitched siren features a unique rotor and stator design that produces a distinctive tonal quality.

The universal motor operates on 120VAC or 125VDC. This siren features oversized ball bearings which are lubricated for the life of the siren, eliminating periodic maintenance.

The Model AX is approved for use in Class I, Division 1, Groups C and D; Class II, Division 2, Groups E, F, & G; and Class III locations. This siren is also UL Listed and CSA Certified.

Model	Voltage	Operating Current	Decibels @		Frequency
			10'	1m	
AX	120VAC/VDC	1.25 amps	112	122	1830Hz



EXPLOSION PROOF ALARM SIREN (AX)

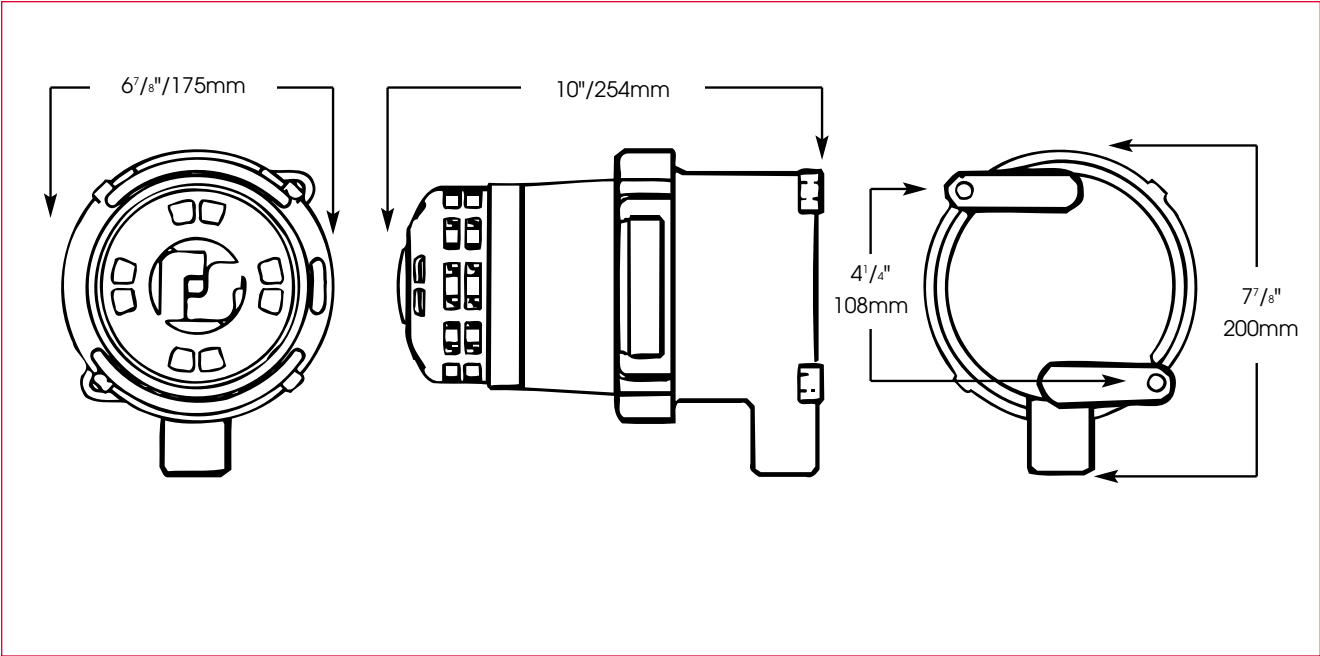

SPECIFICATIONS

Operating Temperature:	-13°F to 104°F	-25°C to 40°C
Motor:	Universal	Universal
Net Weight:	10 lbs	4.5 kg
Shipping Weight:	13.4 lbs	6.1 kg
Height:	7.88"	200 mm
Width:	6.88"	175 mm
Depth:	10"	254 mm

HOW TO ORDER

- Specify model